



racking
systems

STORAX

COMPANY

50 years of experience

Leadership and continuous innovation

Specialists in storage solutions from the simple adjustable rack to the most complex automated warehouse



In 1935 Francisco Ramada founded a small company, F. RAMADA, devoted essentially to the production and marketing of saws and tools.

This small firm progressively created and developed other activities and, in 1958, it introduced the first Slotted Angle, under the licence of Dexion Ltd. Its close ties with Dexion Ltd. enabled it to benefit from the constant innovation and technology provided by Dexion. In latter years RAMADA have developed the basic product range to provide a Europe wide solution.

Today, F. Ramada is the largest manufacturer of warehouse system solutions in Portugal. It offers a range of products and services to the most advanced international firms in the sector, for whom quality, diversification and innovation are of vital importance.

Within the ambit of its strategy of internationalisation and product diversification, the Ramada Group acquired two companies specialised in cold storage, Storax Racking Systems, Ltd (**STORAX**), based in the United Kingdom and B.P.S. Equipements, S.A. (**BPS**), based in France.

Recently, RAMADA GROUP created the company STORAX based in Belgium.

The Group (Ramada, BPS and Storax) is now world leader in cold storage solutions.

F. RAMADA holds the chair of the Portuguese Technical Committee of FEM and actively participates in defining and drawing up the rules and good practices of the ERF (European Racking Federation).

Member of the
European Racking
Federation



 **RAMADA**
SISTEMAS DE ARMAZENAGEM

BPS

STORAX

CLIENTS

PORTUGAL

Novagrês
Vulcano
Nestlé
Pingo Doce
Recheio

Makro
Milaneza
Conforama
Frigoservice
SDF

Pecol
Teka
Soporcel
Bial
Sovena
Vista Alegre

Siemens
Ford Electrónica
Renault
Simoldes
Colep
Transp. Luís Simões

Alliance Unichem
Sony
Revigres
Gelpelke
Renova



UNITED KINGDOM

Cold Move
Christian Salvesen
Grocontinental
Innovate
Reed Boardall
Turners
Yearsley

SPAIN

SDF
Pescanova
Eduardo Vieira
Logista
DHL
Cortefiel

FRANCE

Condigel
Olano
Godfroy
Stef Wimille
Panavi
Lactel
Cooperl
Siemens

NETHERLANDS

Middelkoop
Christian Salvesen
Jumbo Supermarkten
Ostoy Trading
Grolleman

GERMANY

Muk
Dortmunder Kühlhauser
Wojnar's Wiener
BASF

BELGIUM

Hesbaye
Mond TDG
North Freeze
Billiet Vanlaere
Egemin
BNFW
Crop's
Frigo Lommel
Lantmännchen Unibake Londerzeel

ITALY

Gelit
Eskigel
Pescamar

BRASIL

Perdigão
Frangosul

CONVENTIONAL RACKING

Traditional adjustable pallet racking system, which can accommodate most weights and sizes at load.

Different pallet heights can be stored within each bay

Allows direct access to each pallet position.



Accessories ▼

- Pallet support bar
- Shelf support bar
- Steel shelf pannels
- Skid channels
- Coil support bars
- Upright protector
- Frame protection

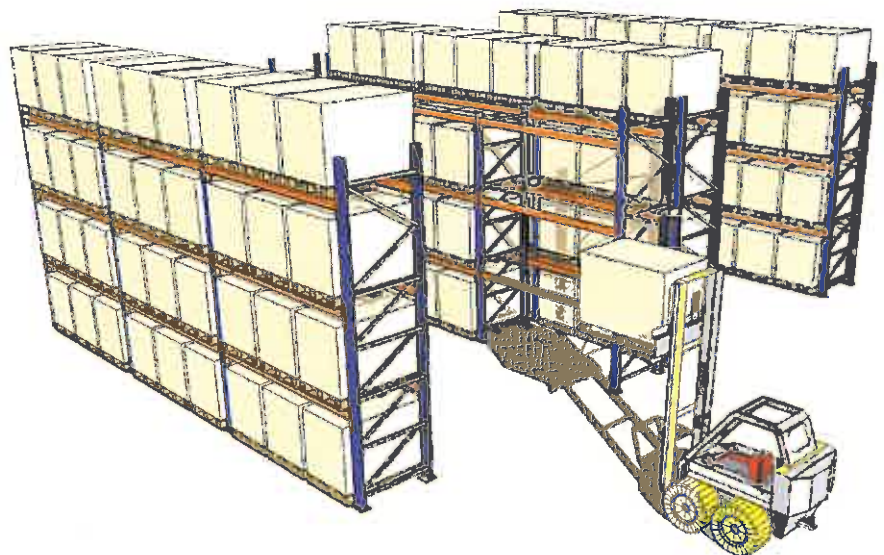

DRIVE IN

High-density compact storage system.

Ideal for homogenous products with high stock rotation that do not require the FIFO system.

Maximises use of available space .

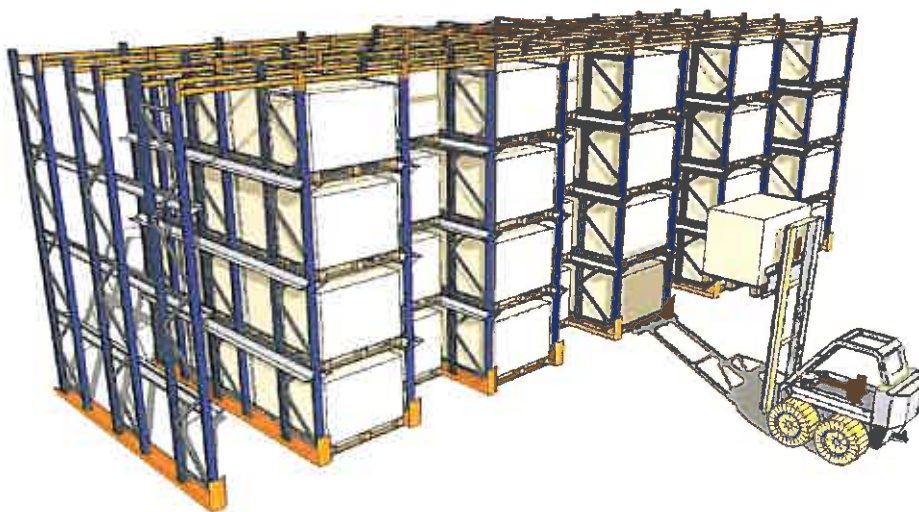

▼ Pallet Support Rail



▼ Pallet Guide-In



MOBILE RACKING

Storage in which static pallet racking is installed on electrically powered bases that move on rails fitted in the floor.

Only needs a single operating aisle. The bases are moved by the operator to gain access to the required stock location.

Ideal solution for cold stores.



Floor preparation ▼

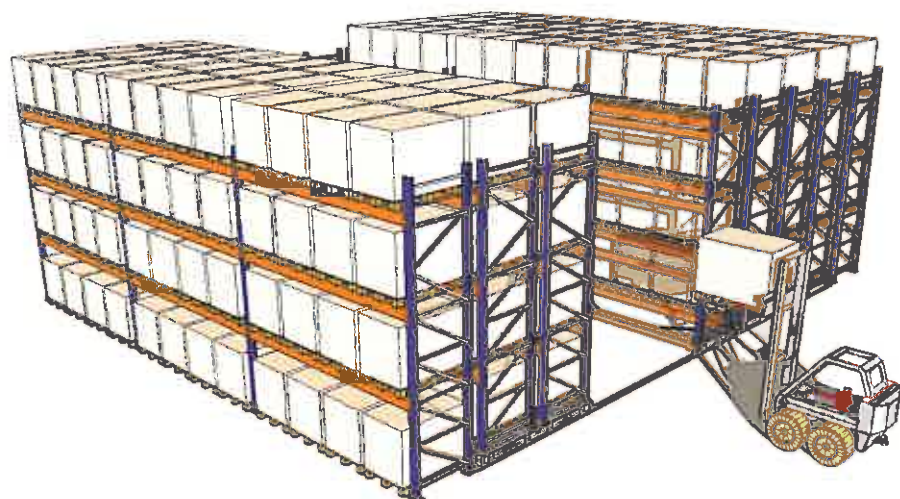
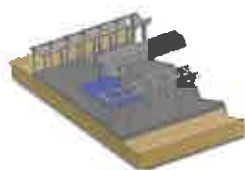
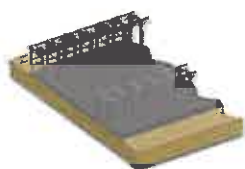

CLAD RACK BUILDINGS AUTOMATED WAREHOUSES

Rack clad buildings are solutions in which the storage structure itself supports the external building walls and roof.

Automated warehouses operate using mechanised storage and retrieval systems.

Both of these solutions usually involve a high level of automation and computerised stock management systems.

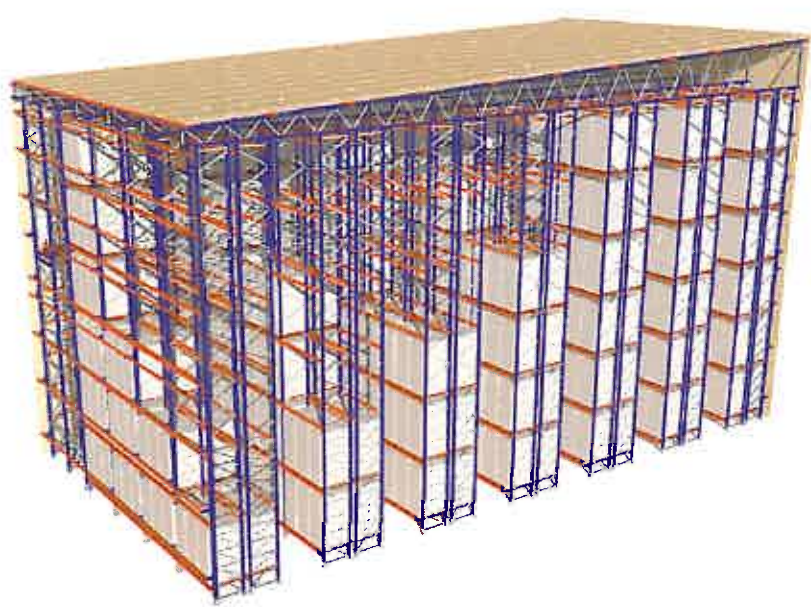
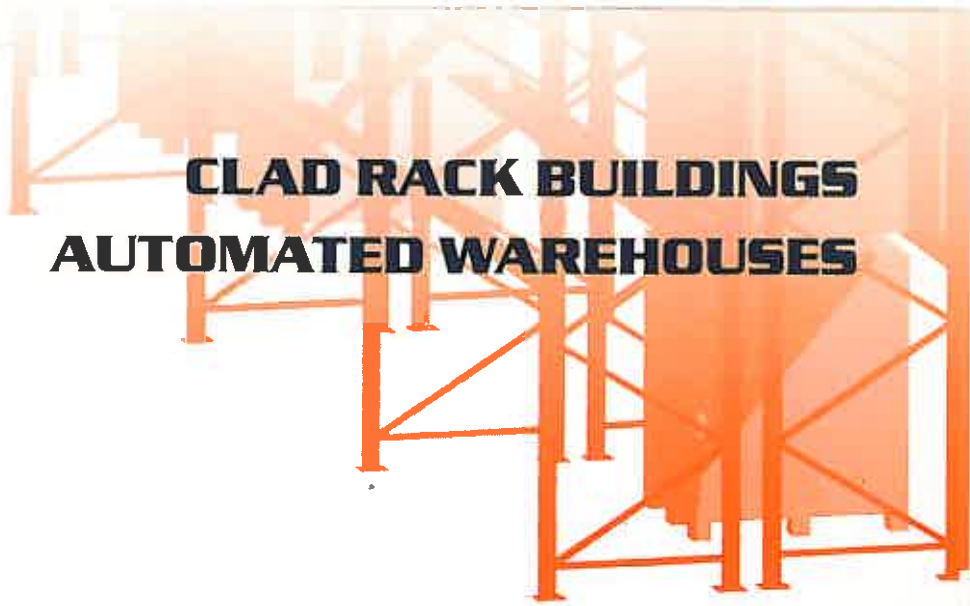

▼ **Install detail**



DYNAMIC RACKING

Gravity-fed storage system. Pallets are loaded at the onload end of the lanes and travel along rollers under the force of gravity to the offload face.

Operating space is only needed in the on load and offload areas.

Provides storage according to FIFO sistem.

The structure is formed by a pallet racking framework supporting conveyor beds in each lane.



Brake ▼



Offload/Inload detail palletes ▼

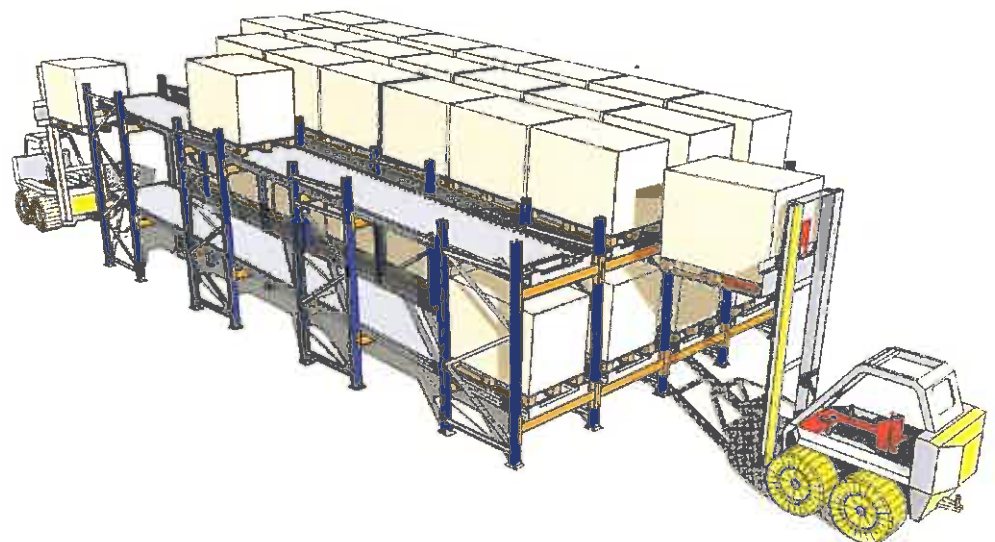

Gravity-fed system in which all pallets are stored and retrieved from the same face.

Up to 4 pallets can be stored and/or retrieved without the fork-lift truck having to drive into the racks.

Provides storage according to Lifo System.

Created by adapting normal pallet racking to accommodate telescopic, nesting pallet trolleys.

PUSH BACK

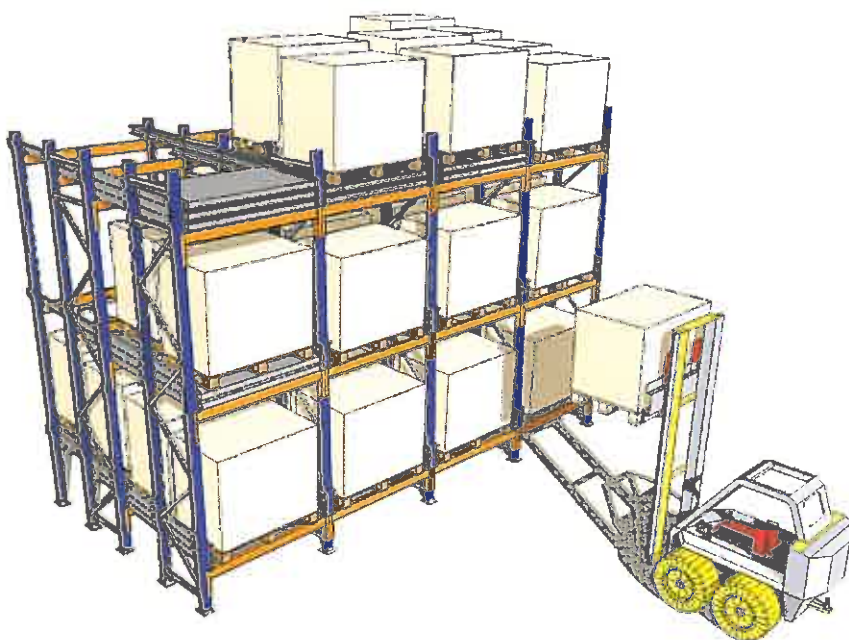
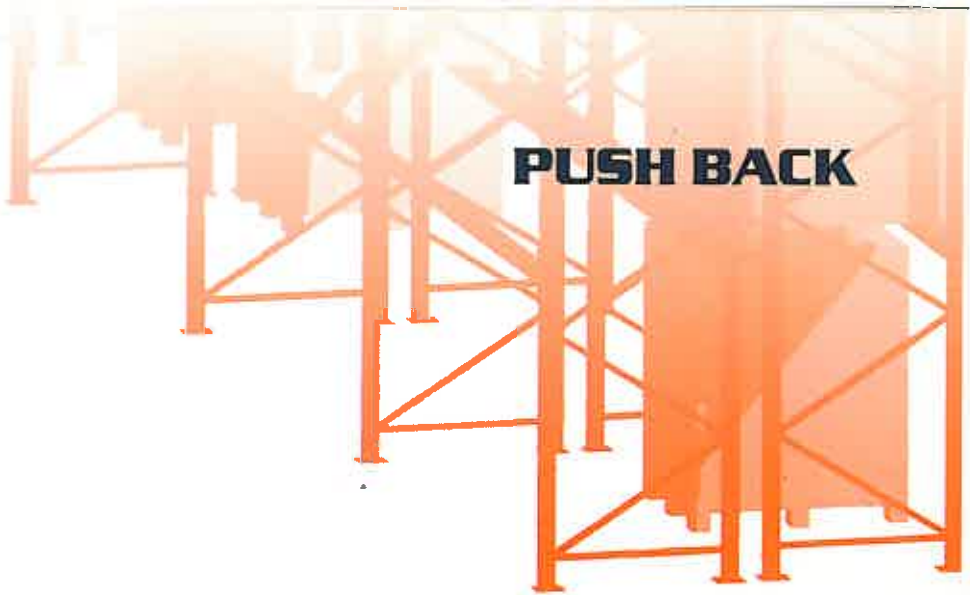

▼ Trolleys runners

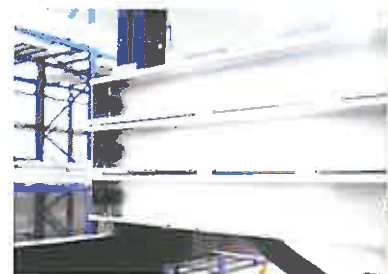

▼ Trolleys

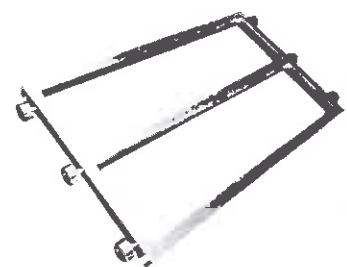

GARMENT HANGING SYSTEM

System designed for static or dynamic storage of textile clothing and its manual or automatic handling.

In this solution there can be various floor levels with the clothing transported between floors by means of motorised conveyors.



Handling detail ▼

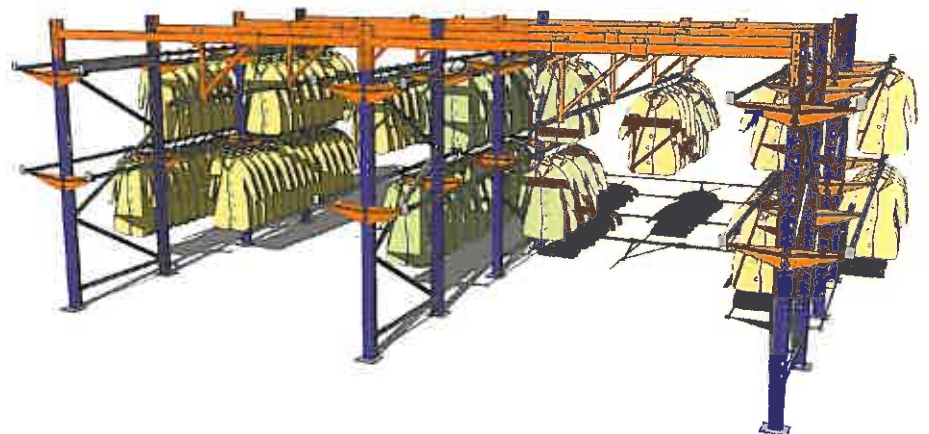

MEZZA NINE

Ideal solution for making the most of the useful available height.

Compatible with the use of other solutions, such as conventional shelving, hanging storage, and others.



▼ Door Gate

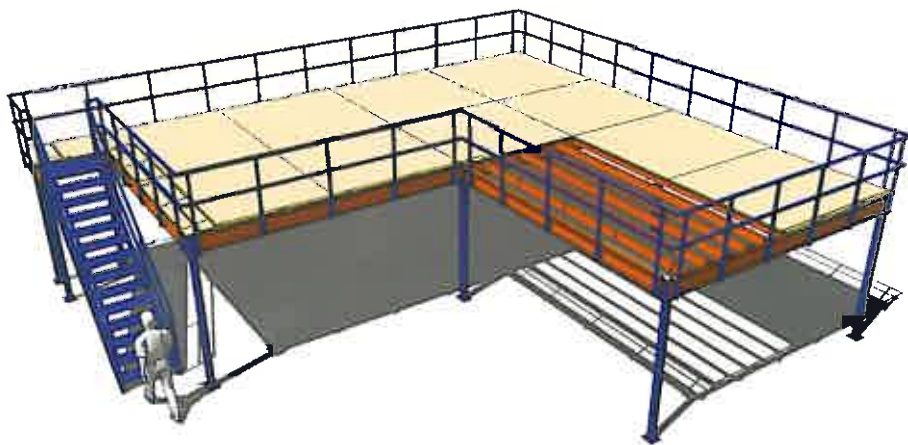

SLIDING DRAWER

Storage system designed specially for moulding-tool or machine-tool storage.

Materials are stored in a drawer type system that ensures rapid access.

Top level of rack provides additional static storage.

Maximum load per drawer of 1000 Kg.

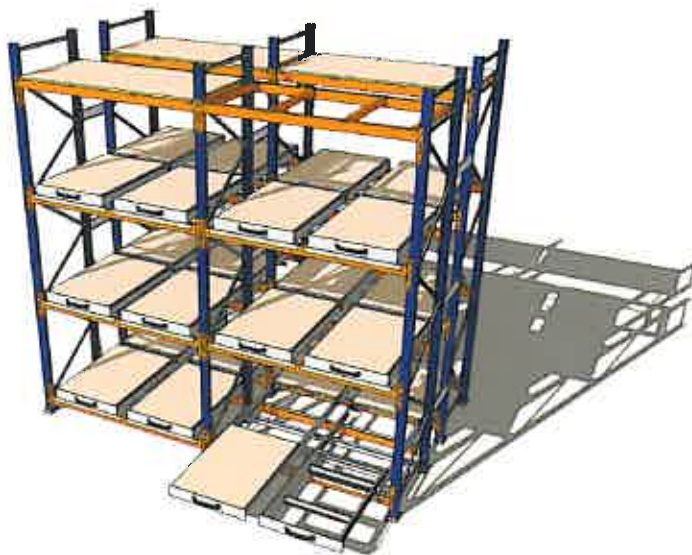

▼ Bearing Lane



Specially suited for storing large, bulky loads, though it is versatile enough to be adapted to any needs.

CANTILEVER



Cavilha ▼

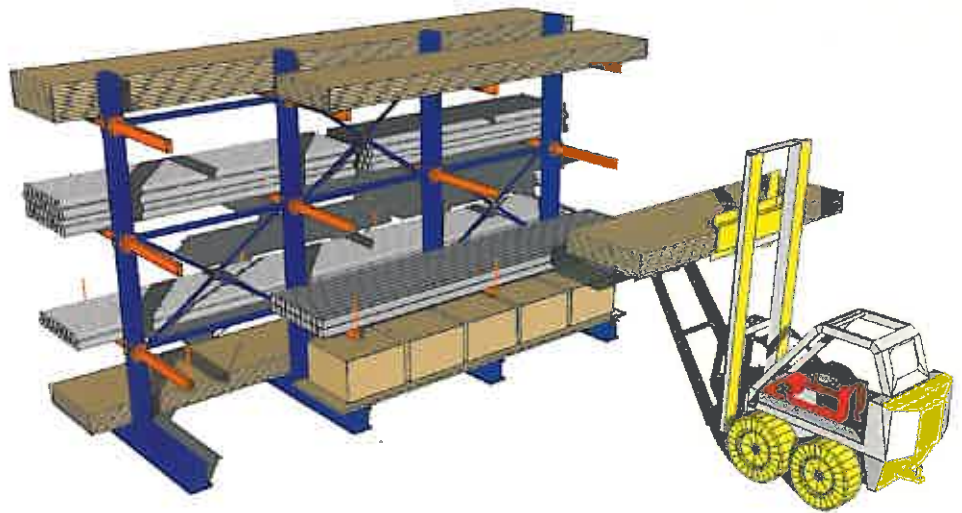



SEDE: OVAR - APART. 74
3884-908 OVAR
Tel: +351 256 580 400
Fax: +351 256 586 054

LISBOA:
Estr. Consiglieri Pedroso, 80 - Lote 2 - A7
Queluz de Parque, Queluz de Baixo
2745-553 BARCARENA
Telefs. +351 214 349 710
Fax: +351 214 348 717
sist.armazenagem@ramada.pt
www.ramada.pt

STORAX BENELUX SA
51, Rue de Huy, 4300
Wareme Borgworm,
Belgium
Tel: +32 19 329 537
Fax: +32 19 329 513



STORAX Racking Systems:
Storax House, Buntsford Park Road,
Bromsgrove
B60 3DX - UK
Tel: +44 1527 573170
Fax: +44 1527 573144
www.storaxsystems.com

STORAX Racking Supplies
2 Frogmore Road, Hempstead
Hemel Hempstead
Herts HP3 9RJ - UK
Tel: +44 1442 229210
Fax: +44 1442 289735



BPS EQUIPEMENTS
4, Avenue de la Ballique, S11c 501-811
91978 Courtabouef Cedex,
France
Tel: +33 160 923 460
Fax: +33 169 077 815
www.bps-equipements.com